

S130 SKID-STEER LOADER



Bobcat[®]
Courtesy of Machine.Market

SKID-STEER LOADER S130

PERFORMANCE S130

Rated operating capacity	600 kg
Tipping load	1200 kg
Hydraulic pump capacity	64 l/min
Travel speed	11.8 km/h
Operating weight	2268 kg

ENGINE

Make/Model	Kubota V2203-M-DI-E2B-BC-3
Fuel/Cooling	Diesel / Water
Power at governed RPM	34.3 kW (46 HP)
EEC 890/1269 (ISO 9249)	@ 2800 RPM
Engine power class	35.3 kW (48 HP)
Cylinders	4
Displacement	2.2 l
Fuel tank capacity	64 l

DIMENSIONS

Length (with bucket)	3059 mm
Width (with bucket)	1398 mm
Height	1956 mm
Height to bucket pin	2771 mm

OPERATION

Steering and drive	Forward, reverse, travel speed and steering controlled by two hand levers
Hydraulics	Two foot pedals or advanced hand controls raise/lower lift arms and dump/rollback bucket
Transmission	Hydrostatic four-wheel drive

STANDARD FEATURES

- Automatically activated glow plugs shutdown
- Bobcat Interlock Control System (BICS™)
- Bob-Tach
- EC Certification
- Foot pedals hydraulics
- Front auxiliary hydraulics
- Horn
- Lift arm support
- Meters/gauges/warning lights/engine shutdown
- Operating lights (front & rear)
- Operator cab (ROPS/FOPS 1)
- Parking brake
- Seat bar
- Seat belt
- Spark arrestor muffler
- Suspension seat (vinyl cover)
- Top, rear and side windows
- 10 x 16.5, 8 ply standard duty tires

OPTIONAL FEATURES

- Advanced Control System
- Advanced Hand Controls (AHC)
- Attachment control kit
- Backup alarm
- Cab door
- Catalytic purifier
- Deluxe instrumentation with keyless start system
- Fresh air heater
- Hydraulic bucket positioning
- Lift kit
- Rear auxiliary hydraulics
- Operator cab (FOPS 2)
- Power Bob-Tach
- Suspension seat (cloth cover)
- 7.50 x 15 segmented industrial tires
- 10 x 16.5 segmented flotation tires
- 31 x 15.5 x 15 super flotation tires
- 10 -16.5, 10 ply Bobcat heavy duty off-set

ATTACHMENTS AVAILABLE

- Angle broom *
- Angle blade
- Auger
- Backhoe
- Buckets
- Brush cutter
- Chipper
- Combination bucket
- Dozer blade
- Dumper
- Ejector bucket
- Feeding bucket
- Front scarifier
- Grader
- Grapples & forks
- Hydraulic breaker *
- Hydraulic fork positioner
- Landplane
- Landscape rake
- Mixing bucket
- Pallet forks
- Planer *
- Rear stabilizers
- Rotary mower
- Salt & sand spreader
- Snow blower
- Sod layer
- Stump grinder
- Super scraper
- Sweeper *
- Three point hitch
- Tiller
- Tilt-Tatch
- Tracks
- Trencher
- Vibratory roller

*Attachment control kit required.

DIMENSIONS

- All dimensions are in mm.
- Loader equipped with 10 x 16.5 offset tires and low profile bucket

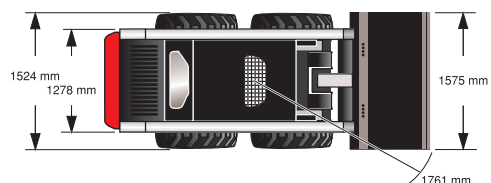
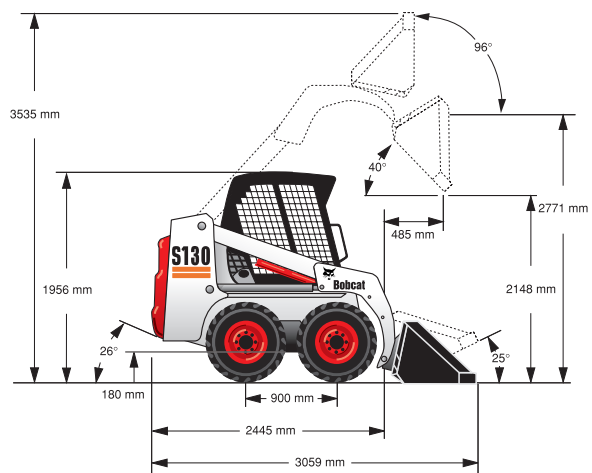

BOBCAT EUROPE

J. Huysmanslaan, 59
B - 1651 LOT Belgium
Tel. +32 (0)2 371 68 11
Fax. +32 (0)2 371 69 01
E-mail: bobcat_europe@eu.bobcat.com
www.bobcat.com

An **IR** Ingersoll-Rand business